

LOTZ CUTTING

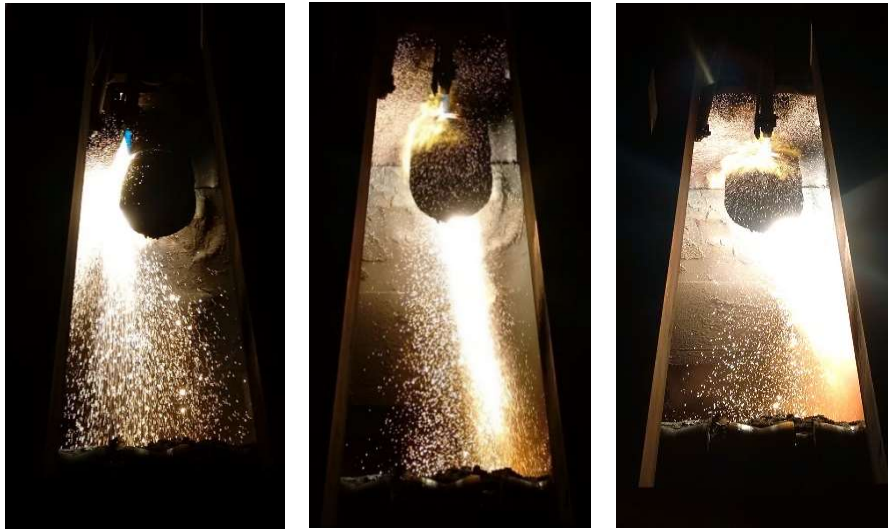

A NEW GLOBAL PLAYER!

PRODUCT PORTFOLIO

IN 2014 THE NAME **LOTZ** RETURNED TO THE STEEL INDUSTRY.
CHALLENGES HAVE BEEN CONQUERED AND GREAT THINGS HAVE BEEN ACHIEVED; YET THERE IS
STILL MORE TO COME.

WE ARE PROUD TO PRESENT THE BEGINNING OF A NEW ERA – THE LOTZ CUTTING ERA!

WITH DECADES OF EXPERIENCE, OUR CONSTANTLY GROWING TEAM IS LOOKING FORWARD TO ASSIST
YOU IN THE AREAS OF OXY CUTTING, DEBURRING AND SCARFING.



TORCH CUTTING MACHINES SPARE PARTS SCARFING SAFETY NON-
RETURN VALVES SLAB CUTTING REPAIRING EXPERIENCE SERVICE
MEASURING ROLLS BEAM BLANK CUTTING DEBURRING CUTTING
NOZZLES BILLET CUTTING ENGINEERING EFFICIENCY CUTTING
TORCHES BLOOM CUTTING OFF-LINE CUTTING SUBDIVIDING
REPAIRING SPARE MACHINES OPTIMIZING UPGRADING EMERGENCY
CUTTER VERTICAL IRON POWDER STAINLESS STEEL CUTTING HAND
SCARFER FLOW CONTROLLERS PRESSURE REGULATORS QUALITY
HEAVY DUTY HEAT PROTECTION DESIGN ECONOMICAL
COMMISSIONING SCRAP CUTTING HOSES GUARANTEED RELIABILITY
APPROVED QUALITY OXY FUEL ECONOMICAL REVAMPING
INNOVATIVE NEW CUTTING MACHINES SPARE PARTS EFFICIENCY

IN THIS PAMPHLET YOU WILL FIND A BRIEF SUMMARY OF OUR PRODUCT RANGE.
PLEASE CONTACT US FOR A FULL SCOPE OF SUPPLY.

EMAIL: sales@lotz-cutting.com

TEL: +49 6122 58648-00

FAX: +49 6122 58648-29

ROBERT-BOSCH-STR. 3 · 65719 HOFHEIM (WALLAU) · GERMANY



CONTENTS

NOZZLES	4
TORCHES.....	5
MANUAL CUTTING TORCHES	6
VALVES.....	7
REGULATORS	8
SCARFING EQUIPMENT.....	11
HOSES	11
SAFETY EQUIPMENT	12
IRON POWDER EQUIPMENT	12
EXTERNAL PILOT BURNER.....	13
PRESSURE CONTROL DEVICES	13
DURASTEEL®	14
SERVICE.....	15
MISCELLANEOUS	16
INNOVATION	16
SUMMARY	17
BRAND LISTING.....	18

NOZZLES

USING OUR DECADES OF EXPERIENCE AS THE WORLD LEADER, WE HAVE CREATED A PRODUCT OF THE HIGHEST QUALITY WITH EXCEPTIONAL CHARACTERISTICS.

THE OCL AND OCH CUTTING NOZZLES ARE SURE TO IMPRESS WITH THEIR EXCELLENT SURFACE AND CUTTING-EDGE QUALITY, SMALL CUTTING KERF, HIGH CUTTING SPEED AND A LONG SERVICE LIFE.

THE MOST FREQUENTLY USED AND APPROVED:



OCH



OCL

TYPE	CUTTING THICKNESS RANGE (MM)
OCH 32 (P)	50 - 250
OCH 35 (P)	50 - 350
OCH 39	50 - 500
OCH 41	50 - 300
OCL 10	25 - 500
OCL 12	25 - 500
OCL 26	50 - 400
OCL 26 P	50 - 400
OCL 36	50 - 500
OCL 36 P	50 - 500
OCL 40	50 - 500
OCL 40 P	50 - 500
OCL 51	350 - 650
OCL 61	350 - 800

P = CUTTING WITH IRON POWDER

(P) = CUTTING WITH AND WITHOUT IRON POWDER

OTHER CUTTING NOZZLES SUCH AS HOT OR STD NOZZLES AVAILABLE ON REQUEST.

TORCHES

THE APPROVED, WATERCOOLED TO THE TIP, CUTTING TORCHES ARE SETTING THE STANDARD FOR A WORKING TOOL IN SUCH A HARSH ENVIRONMENT.
THIS HIGH QUALITY TOOL, TYPE OCT/OCC/OCK, IS DESIGNED FOR THE USAGE WITH CUTTING MACHINES AND IS APPLICABLE TO ALL OCH AND OCL NOZZLES.

MAIN CHARACTERISTICS
WATER-COOLED SHAFT PIPE 50MM
APPLICABLE TO NOZZLE TYPE: OCL26 (P) OCL36 (P) OCL40 (P) OCL51 OCH32 OCH35 OCH39
AVAILABLE 400 TO 2000MM IN INCREMENTS OF 100MM (OTHER LENGTHS ON REQUEST)
CONNECTION CUTTING OXYGEN G1/2" HEATING OXYGEN G3/8" HEATING GAS G1/2" LH COOLING WATER INLET G3/8" COOLING WATER OUTLET G3/8"



OCT



ADDITIONAL CUTTING TORCHES FOR THICK MATERIAL CUTTING OR MOBILE CUTTING SYSTEMS AND SPECIAL APPLICATIONS IS AVAILABLE ON REQUEST.



OCK TORCH FOR MOBILE CUTTING

MANUAL CUTTING TORCHES

THE CUTTING TORCH OCA (A=ANGLED 90°) IS MAINLY USED FOR THE EMERGENCY CUTTING OF SLABS, BLOOMS, BILLETS AND BEAM BLANKS IN STRAND CASTING LINE DURING THE PRODUCTION. ITS LOW WEIGHT AND YET ROBUST DESIGN CONVINCES EVERYONE ON THE SHOP FLOOR WHERE IT IS ESSENTIAL TO HAVE A RELIABLE TOOL WITH A LONG SERVICE LIFE.



OCA

MAIN CHARACTERISTICS	
LENGTH	STANDARD 1500 TO 3500 MM (OTHER LENGTHS ON REQUEST)
DESIGN	APPLICABLE TO NOZZLE TYPE: OCL26 (P) OCL36 (P) OCL40 (P) OCH32 OCH35 OCH39
WEIGHT	4.5 KG ONLY AT 1500MM LENGTH
CUTTING THICKNESS	STANDARD 50 – 500 MM
CONNECTIONS	OXYGEN G1/2" GAS G3/8" LH



OTHER TYPES, FOR CUTTING SCRAP, CUTTING WITH IRON POWDER OR NON-ANGLED EMERGENCY CUTTERS ARE ALSO AVAILABLE.



VALVES

THE GAS FLOW CONTROLLER TYPE 5588 SERVES THREE MAIN FUNCTIONS.

1. CONTROLS PRECISELY THE FLOW OF THE MEDIA.
2. SHUTS OFF THE MEDIA.
3. IF REQUIRED (ON CERTAIN ASSEMBLIES) IT CAN GIVE A SMALL CONTROLLABLE BYPASS FLOW OF MEDIA FOR A PILOT FLAME.

THIS PRECISION TOOL ALLOWS A FINE ADJUSTMENT OF THE MEDIA FLOW, AND SHOULD BE INSTALLED CLOSE TO THE CUTTING TORCH FOR THE BEST CUTTING RESULT.

MAIN CHARACTERISTICS	
BODY MATERIAL	BRASS
MAX OPERATING PRESSURE	25 BAR
MIN OPERATING PRESSURE	0.5 BAR
COIL VOLTAGE	REGIONALLY DEPENDENT - MOST AC & DC VOLTAGES AVAILABLE
FOR THE USE WITH	PROPANE, NATURAL GAS, ACETYLENE AND OXYGEN



OVERVIEW

TYPE	
FCA 5588	NO BYPASS – WITH GAUGE PORT ASSEMBLY
FCB 5588	WITH BYPASS NEEDLE VALVE (TYPE 881)
FCC 5588	WITH SOLENOID OPERATED BYPASS NEEDLE VALVE (TYPE 882)
FCD 5588	WITH BYPASS NEEDLE VALVE (TYPE 881), EXTERNAL BYPASS ADAPTOR & GAUGE PORT ASSEMBLY
FCE 5588	WITH SOLENOID OPERATED BYPASS NEEDLE VALVE (TYPE 882) AND EXTERNAL BYPASS OUTLET.

OTHER VALVES FOR YOUR GAS/ MEDIA REGULATION SYSTEM ARE ALSO AVAILABLE.

REGULATORS

LC PRESSURE REGULATOR

THE LC REGULATOR IS DESIGNED FOR USE WITH GAS AND OXYGEN FOR VARIOUS FIELDS OF OPERATION. ACCURATE ADJUSTMENT OF THE OPERATING PRESSURE AND LONG LIFE SPAN RESULT FROM THE SOLID CONSTRUCTION OF THIS UNIT, EQUIPPED WITH HIGH QUALITY AND PRECISE ADJUSTMENT MECHANISM. THE PERFECT MATCH FOR THE HARSH ENVIRONMENT OF A STEEL PLANT.

THE BASIC LC REGULATOR HAS ALL NECESSARY ADJUSTING AND MEASURING DEVICES IN ONE UNIT. THROUGH ADDITIONAL DEVICES, THE FEATURES CAN BE EXTENDED, FOR EXAMPLE FOR THE USE FOR TWO CONSUMING DEVICES SUCH AS CUTTING TORCHES OR AN INTEGRATED PILOT FLAME.

MAIN CHARACTERISTICS	
BODY MATERIAL	BRASS
MAX OPERATING PRESSURE	40 BAR
MIN OPERATING PRESSURE	0.5 BAR
COIL VOLTAGE	REGIONALLY DEPENDENT - MOST AC & DC VOLTAGES AVAILABLE
FOR THE USE WITH	PROPANE, NATURAL GAS, ACETYLENE AND OXYGEN



UNITS WITH SINGLE PRESSURE OUTLET

	TYPE
HEATING GAS	LC1S
	LC1S/MS
	LC1S/MCG
	LC1S/MSG
HEATING OXYGEN	LC2S
	LC2S/MS
	LC2S/MCG
	LC2S/MSG
CUTTING OXYGEN	LC3S
	LC3S/M

UNITS WITH DOUBLE PRESSURE OUTLET

	TYPE
HEATING GAS	LC1SD
	LC1D/MS
	LC1D/MCG
	LC1D/MSG
HEATING OXYGEN	LC2D
	LC2D/MS
	LC2D/MCG
	LC2D/MSG
CUTTING OXYGEN	LC3D/M

ALSO AVAILABLE, MAINTENANCE KITS AND REPAIRING SERVICES.



DOMESTIC PRESSURE REGULATOR DR42

THE DOMESTIC PRESSURE REGULATOR IS PARTICULARLY SUITABLE FOR MOUNTING IN SUPPLY PIPEWORKS FOR CENTRAL GAS SUPPLIES. INDEPENDENT OF WITHDRAWAL FLUCTUATIONS THE STABILITY OF THE WORKING PRESSURE GUARANTEES A CONSTANT QUALITY OF THE DOWNSTREAM PROCESS. ADDITIONALLY THE USE IN CASE OF HIGH FLOW RATES AT LOW PRESSURE DROPS RECOMMENDED.

CONNECTING DIMENSIONS MAY VARY. WITH FLANGE CONNECTION (F) OR WITHOUT BUT WITH THREAD CONNECTION (G). ALSO AVAILABLE, MAINTENANCE KITS AND REPAIRING SERVICES AND OTHER MODELS.

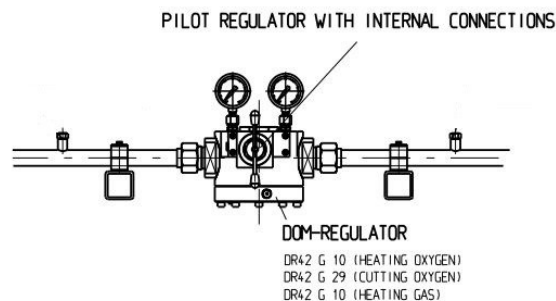

LEFT →	OXYGEN	DR42G10	DR42G29	DR42F10	DR42F29
RIGHT	GAS	DR42G10LH	DR42G29LH		
GASES:		Ar, N ₂ , H ₂ , O ₂ , He, CO ₂			
MAX. INLET PRESSURE:		O ₂ : 30 BAR CO ₂ : 25 BAR OTHER GASES: 40 BAR			
MAX. PILOT PRESSURE:					
CO ₂ :		10 BAR	16 BAR	10 BAR	16 BAR
OTHER GASES:		10 BAR	30 BAR	10 BAR	30 BAR
MAX. OUTLET PRESSURE:					
O ₂ :		10 BAR	29 BAR	10 BAR	29 BAR
CO ₂ :		10 BAR	16 BAR	10 BAR	16 BAR
OTHER GASES:		10 BAR	30 BAR	10 BAR	30 BAR
INLET CONNECTION:		G 1 ¼, G1 ¼ LH		DN50 PN40 (O-RING)	
				DN50 PN40 (PLAIN)	
OUTLET CONNECTION		G 1 ¼, G1 ¼ LH		DN50 PN40 (O-RING)	
				DN50 PN40 (PLAIN)	
MATERIAL:		HOUSING - BRASS CARTRIDGE – STAINL. STEEL MEMBRANE – CR			
WEIGHT APPROX.		17 KG		26 KG	

BENEFITS

- COMPLETELY MOUNTED, INCLUSIVE PRESSURE GAUGE, PILOT PRESSURE REGULATOR AND FITTINGS
- ANYTIME CHANGEABLE WORKING PRESSURE (READJUSTABLE) E.G. AT FLUCTUATION OF TEMPERATURE
- PROVIDES CONSTANT WORKING PRESSURE BY DYNAMIC CONTROL
- NO DISPENSE OF PILOT GAS TO THE ENVIRONMENT DUE TO CLOSED SYSTEM
- INDOOR AND OUTDOOR INSTALLATION
- CONNECTION FOR WALL MOUNTING PANEL
- EASY INSTALLATION AND REMOVING

SCARFING EQUIPMENT

LOTZ CUTTING HAS A HUGE RANGE OF SCARFING EQUIPMENT FOR THE SURFACE FINISHING PROCESS AVAILABLE.

BESIDES COMPLETE SCARFING MACHINES, MANIPULATORS AND HAND SCARFERS, ALSO SPARE BURNERS, NOZZLES AND THE RECONDITIONING OF THOSE IS OUR BUSINESS.



HOSES

HOSES MUST COMPLY WITH CERTAIN TECHNICAL REQUIREMENTS.

OUR HOSES ARE SPECIALLY DESIGNED FOR THE HARSH ENVIRONMENT OF A STEEL PLANT, WORKSHOP TESTED AND "BAM" CERTIFIED.

TYPES AVAILABLE:

2SS FOR OXYGEN

2SG FOR GAS

2TE FOR WATER AND AIR

3TE FOR WATER AND AIR

PTFE FOR VARIOUS MEDIA AND IRON POWDER



...OR COMPLETE CONFIGURATED DRAG CHAIN WITH ALL NECESSARY HOSES AND CABLES FOR YOUR MACHINE?



SAFETY EQUIPMENT

OUR SAFETY DEVICES AND NON-RETURN VALVES PROVIDE THE SAFETY FEATURE REQUIRED FOR YOUR OXYFUEL EQUIPMENT.

OUR HIGH QUALITY CERTIFIED SAFETY DEVICES AND VALVES ARE AVAILABLE IN MANY DIFFERENT SIZES FOR GAS AND OXYGEN, AND A HUGE PRESSURE RANGE.

TYPES AVAILABLE:

LG/GRM /S /D
SIMAX 4/ 5/ 8/ LG
DEMAX 5
GRV

FOR DETAILS OR OTHER MODELS, PLEASE CONTACT US.



IRON POWDER EQUIPMENT

FOR CUTTING STAINLESS STEEL, WE HAVE ALL PRODUCTS NEEDED FOR MACHINE OR MANUAL CUTTING. OUR SCOPE OF SUPPLY RANGES FROM THE POWDER TANKS, HOSES AND PIPES, POWDER INJECTORS, PINCH VALVES, POWDER FEEDERS, AND MANY MORE FOR YOUR STATIONARY OR MOBILE CUTTING EQUIPMENT.

MOREOVER, WE PROVIDE THE BEST IRON POWDER TO GUARANTEE THE BEST CUTTING RESULT.



EXTERNAL PILOT BURNER

THE EXTERNAL PILOT BURNER ALLOWS THE SAFE IGNITION OF THE CUTTING TORCH ON THE MACHINE. ONCE IGNITED, THIS DEVICE PROVIDES A PERMANENT FLAME USING A SMALL AMOUNT OF GAS ONLY AND THE OXYGEN FROM THE AMBIENT AIR.

MAIN CHARACTERISTICS	
LENGTH	STANDARD 300 TO 1500 MM
APPLICATION	MOUNTED ON CUTTING TORCH
PRESSURE	NATURAL GAS 80 – 120 MBAR PROPAN 60 – 80 MBAR
CONNECTION	GAS G1/2" LH



IGNITION TORCH FOR AUTOMATIC IGNITION OF THE PILOT BURNER AND THE INSTALLATION AND INTEGRATION OF THE PROGRAM UPDATE AVAILABLE.

PRESSURE CONTROL DEVICES

NOT ONLY FOR SAFETY REASONS BUT ALSO FOR THE PERFECT PRESSURE ADJUSTMENT IT IS REQUIRED TO HAVE THE RIGHT TOOLS. THE PRESSURE GAUGES ARE AVAILABLE WITH DIFFERENT CONNECTORS OR MEASURING DEVICES THAT CAN BE INSTALLED DIRECTLY AT THE CUTTING TORCH.

MEDIA	PRESSURE RANGE (BAR)
GAS	0 - 2,5
	0 - 4
	0 - 10
	0 - 25
OXYGEN	0 - 4
	0 - 10
	0 - 25
	0 - 40



OTHER PRESSURE GAUGES WITH DIFFERENT CONNECTION TYPES OR ADDITIONAL EQUIPMENT ARE ALSO AVAILABLE.



DURASTEEL®

THE DURASTEEL® PLATES MADE OF CEMENT-BONDED COMPOSITE PANEL, REINFORCED ON BOTH SIDES WITH GALVANISED STEEL SHEETS, ARE THE PERFECT PROTECTION AGAINST FIRE AND HEAT RADIATION. OUR AFFILIATED COMPANY “MLFEUERSCHUTZ” HAS BEEN SUPPLYING THE PLATES SINCE THE 60’S FOR VARIOUS FIELDS AND MANY STEEL PLANTS WORLDWIDE.

CUSTOM-MADE

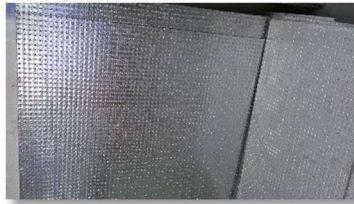

MAIN CHARACTERISTICS	
HUMIDITY	APPROX. 6% (AIR DRY)
ALKALINITY (PH VALUE)	APPROX. 12
HEAT CONDUCTIVITY λ	APPROX. 0.55 W/mK
STANDARD DIMENSIONS	1200 X 2500 MM (\pm 3MM) INDIVIDUAL DIMENSIONS AND FRAMING ON REQUEST
THICKNESS	9.5 MM (\pm 1MM)
WEIGHT	APPROX. 21 KG/M ²
BENDING STRENGTH	80 N/MM ²
COMPRESSION STRENGTH	60 N/MM ²
ELASTIC MODULUS E	APPROX. 40.000 N/MM ²
BUILDING MATERIAL CLASS	NON-FLAMMABLE DIN 4102-A1
SURFACE CONDITION	BOTH-SIDED PERFORATED GALVANISED STEEL SHEET
LANDFILL ABILITY	CAN BE DISPOSED AS RUBBLE (FAK KEY 17 01 04)
STORAGE	DRY CONDITION
THERMAL STABILITY	APPROX. 400° C (LASTING) APPROX. 1000° C (SHORT)
ACOUSTIC INSULATION	AREA 110 – 3150 Hz: 29.9 dB THROUGH THE PANEL

SERVICE

OUR SERVICE INCLUDES:

ENGINEERING
CONSULTATION
UPGRADING
MODIFYING
COMMISSIONING
RECONDITIONING
REVAMPING
REPAIRING
REPLACING
TRAINING
ON-SITE SERVICE



NEW PROJECTS OR REPLACING OLD MACHINES, UPGRADING OR REVAMPING,
WE SUPPORT YOU WITH YOUR DESIGNATED TARGETS.



AS GOOD AS NEW AFTER OUR EXTENSIVE
RECONDITIONING.

MISCELLANEOUS

ADDITIONAL EQUIPMENT AVAILABLE!

AND COMING SOON,

...NEW HAND SCARFER AND MOBILE CUTTING MACHINE.

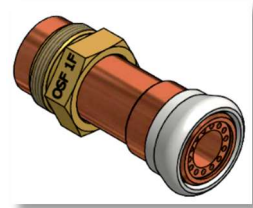

INNOVATION

SEE OUR NEWEST CUTTING MACHINE IN OPERATION.

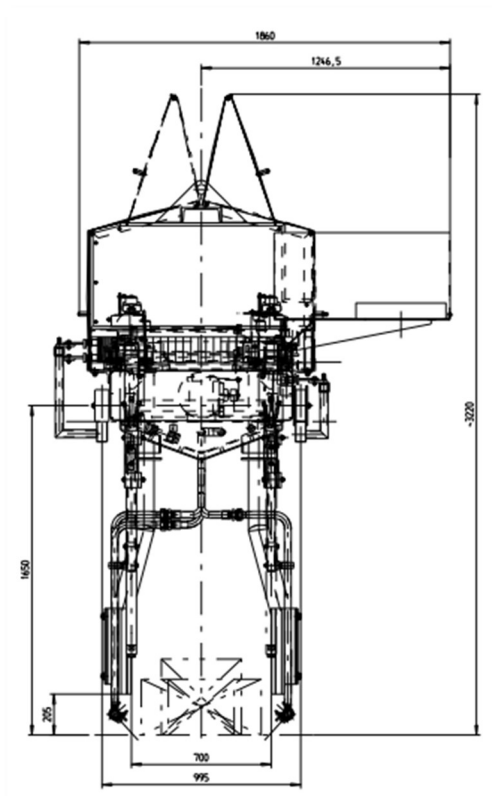

NEWEST DESIGN AND FURTHER DEVELOPMENT FOR A LONGER SERVICE LIFE, GUARANTEED!

SUMMARY

AFTER DECADES OF EXPERIENCE ON TOP OF THIS BUSINESS, IT IS TIME TO MOVE ON AND LEAVE SOME NEW FOOTPRINTS BEHIND.

BESIDES THE LISTED PRODUCTS IN THIS LEAFLET, WE HAVE MUCH MORE TO OFFER.

STILL NOT CONVINCED? GET YOUR FREE QUOTE FOR ANY ITEM NEEDED FOR YOUR MACHINE NOW AND SEE FOR YOURSELF!

EMAIL: sales@lotz-cutting.com

TEL: +49 6122 58648-00

FAX: +49 6122 58648-29

ROBERT-BOSCH-STR. 3 · 65719 HOFHEIM (WALLAU) · GERMANY

REACH YOUR TARGET WITH PRECISION, EFFICIENCY AND QUALITY.

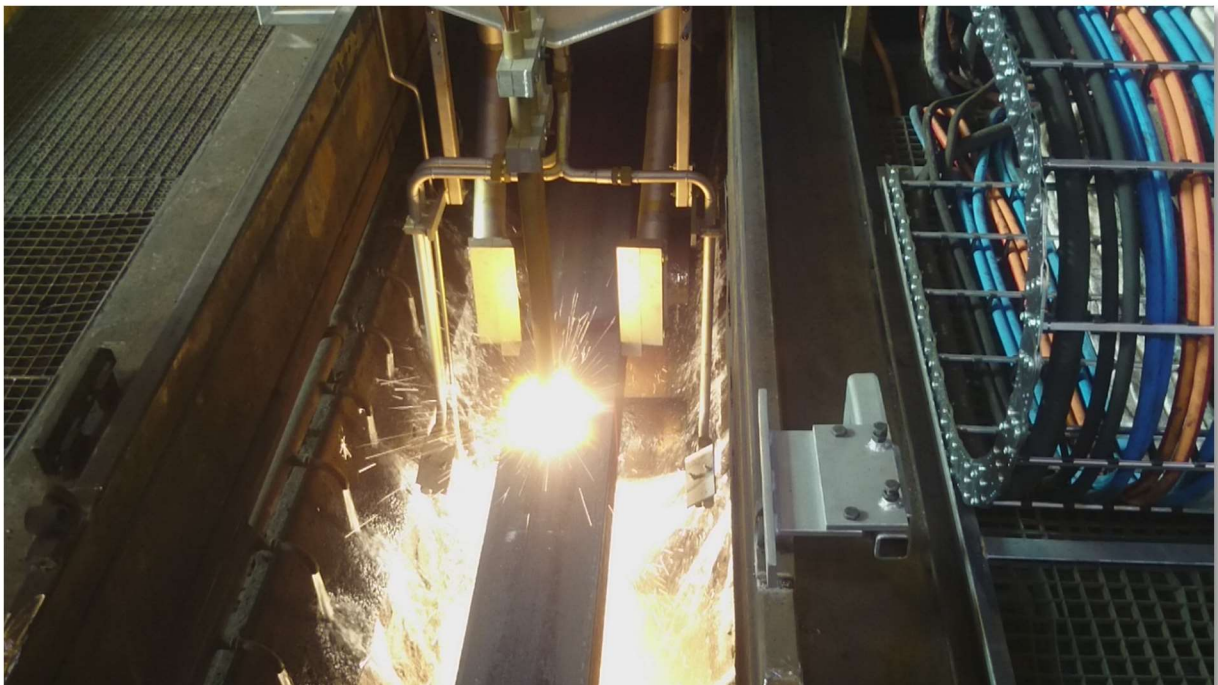

BRAND LISTING

AFTER A SUCCESSFUL LAUNCH AND RECOGNITION, THE BRAND "LOTZ" IS NOW OFFICIALLY REGISTERED.





LOTZ
CUTTING

